

# ABS | Upright Cabinets

REFRIGERATED UPRIGHT ▶ GLASS DOOR ▶ WHITE PAINTED

# QRG 200

<b>GAS</b> R600a			<b>B</b> ENERGY CLASS	<b>3</b> CLIMATIC CLASS	

## DETAILS

<b>Main switch, light switch and digital thermostat fitted as standard</b>	<b>Foamed door handle</b>	<b>Lock fitted as standard</b>
<b>Double vertical LED light along inner door profile</b>	<b>Shelf with small distance between the line and bottom shelf fitted as standard</b>	<b>Inner assistance fan</b>



## GENERAL FEATURES

- 200 Lt. Refrigerated upright (GLASS DOOR)
- White external cabinet, thermoformed internally
- Roll-bond evaporator system with fan assisted cooling
- Automatic compressor cycle defrost
- Foaming Agent Cyclopentane (70mm per side)
- Double safety tempered glass with Low-e (Low emissivity glasses)
- Digital Thermostat
- Independent back-lit main and lights switches (White color)
- Double vertical LED light along door profile
- Removable Gasket and handle along door profile
- Doors lock fitted as standard
- Adjustable shelves: 2 Pcs + 1 BOTTOM Shelf
- N.2 Adjustable feet + N.2 Rollers at the back
- Energy efficiency class: B

## TECHNICAL SPECIFICATIONS

Capacity	200 L
Temperature	+2°C - +10°C
Consumption	1.36 kWh/24h
Rated Power	140 W
Noise level	52 dB(A)
Net Weight	45 Kg
Gross Weight	49 Kg
External Dimensions (WxDxH mm)	600x625x853
Internal Dimensions (WxDxH mm)	458x465x603
Packaging dimensions (WxDxH mm)	640x660x890
Loading quantities 20'/40'/40'HQ	54/108/162

## PRODUCT DIMENSIONS

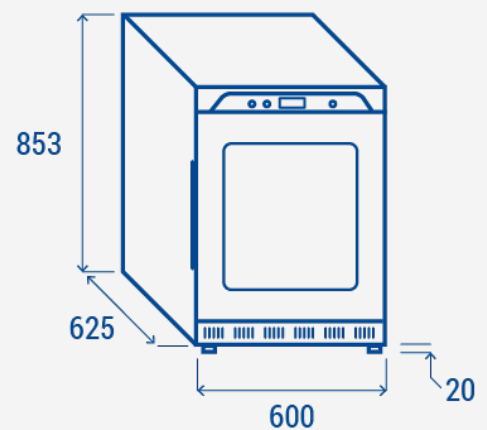

## CERTIFICATION

CE RoHS

